

OWNER'S MANUAL

CAMCRUISER® VENDING CARTS

This owner's manual applies to all variations of the following Camcruiser Vending Cart Models:

CVC72

CVC724

CVC55

Congratulations on the purchase of your new Camcruiser Vending Cart. This Owner's Manual provides you with a step by step guide to assembling, and maintaining a Camcruiser Vending Cart. If you have any further questions, please do not hesitate to contact us, visit our website at www.cambro.com or call our Customer Service Dept.



CVC724



CVC72



CVC55

StoreSafe™

CAMBRO
TRUSTED FOR GENERATIONS™

www.cambro.com

I. Part List

Only Applies to CVC72 and CVC724.

1. One cash box with 2 keys.
2. One cash drawer.
3. One menu board.

Applies to CVC55, CVC72 and CVC724.

4. Umbrella.

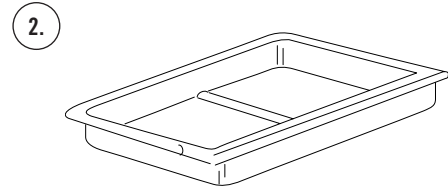
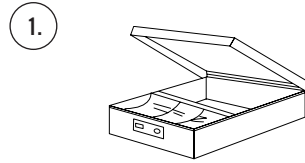

3.

4.



II. Assembly Instructions

A. VINYL UMBRELLA

Before opening the umbrella, turn it upside down and shake out all of the folds.

When packed at the factory, your umbrella was specially folded and rolled to insure against freight damage. "Shake out" is required for first use only.

To Place Umbrella on Cart (Applies to CVC72 and CVC724):

1. Let umbrella pole slowly drop onto center support pole until button snaps into locations hole.

To Place Umbrella on Cart (Applies to CVC55):

1. Lower umbrella pole through mount hole onto aluminum locator mount.

To Remove Umbrella:

1. Depress the retractable button on the umbrella pole.
2. Twist the umbrella pole 1/4 turn to disengage the button.
3. From front of cart reach up the umbrella pole and depress the umbrella latch to lower the umbrella.
4. When the umbrella is lowered, lift the umbrella pole out of the base pole.

To Store:

1. Umbrella should be clean and dry.

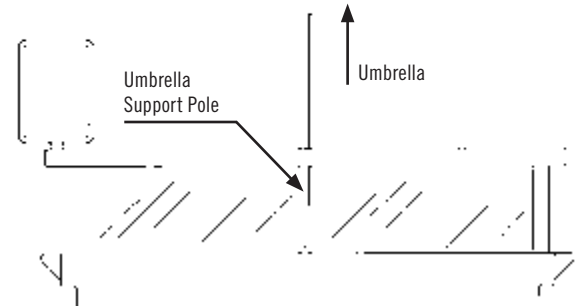

CVC72 and CVC724 Carts

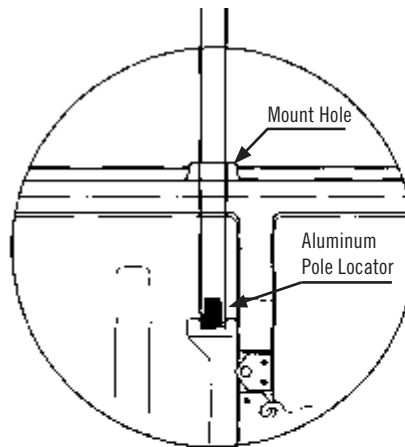

Shown with optional Retainer Strap (730STP)

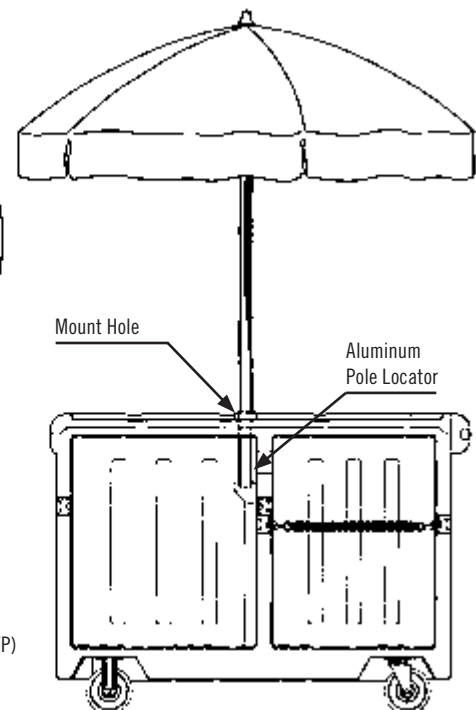

Operators Side

CVC55 Cart

B. MENU BOARD (Only applies to CVC72 and CVC724.)

To Place Menu Board on Cart:

1. Place the base stem located on the bottom of the menu board frame into the hole located on the outside corner of the counter top.
2. Adjust the menu board by turning the frame to the desired position.

To Remove Menu Board:

1. Lift menu board off of the counter top hole.

To Use:

1. Write on glossy white side only. (Wrong side is marked)
2. Use only water soluble markers.
3. Erase marked board with a clean dry cloth or a damp, soapy cloth, if marks persist.

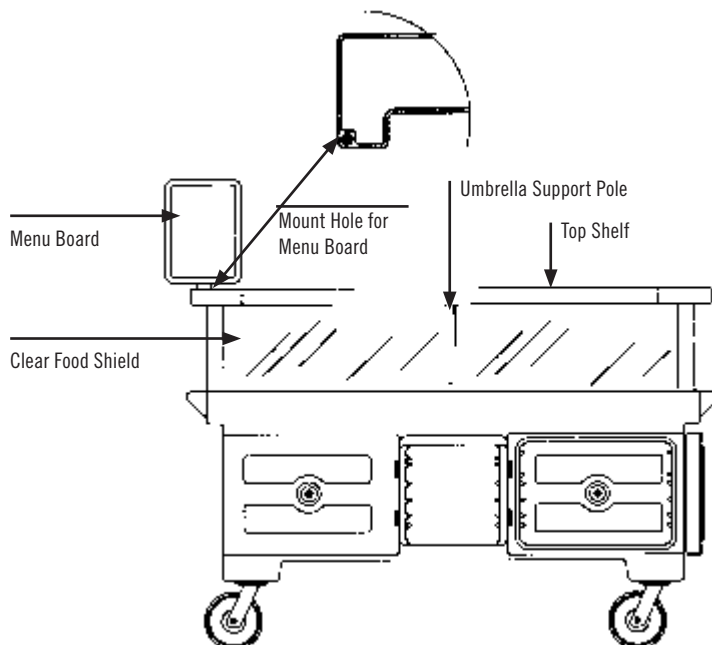

III. Maintenance and Cleaning

The Cambro Camcruiser Vending Cart should be cleaned regularly. Additionally, it should be cleaned before using if it has been idle for 5 days or more.

Camcruiser Cart Body/Display-Serving Shelf/Holding Compartments

Steam clean or wash with warm soapy water and a soft plastic or bristle brush. **NEVER** use a metal brush or abrasive cleaner. Scrub with brush, and rinse thoroughly with clean water. If staining occurs, any standard de-stainer such as Ecolab's "Dip It" should be used.

Clear Plastic Sneeze Guard Shield

Wash the clear plastic shield with warm soapy water. Rinse thoroughly. Dry with soft cloth or soft paper towel.

NEVER use alcohol, i.e. Windex, abrasives, any type of solvent or acetone

Alcohol based cleaners will cause the shield to crack.

Vinyl Umbrella

Spray rinse with water from a hose. Wash with mild detergent and use a sponge or soft brush to remove debris.

Metal Umbrella Pole and Support Pole

Clean frame/uprights with a damp cloth and mild soap. Apply car wax to poles to prevent oxidation.

CASTERS

Caster maintenance should be performed after every cleaning.

1. Grease swivel raceway of caster using a lubricant such as Lubriplate #930-AA, Keystone #84EPXLT multi-purpose grease or equivalent. Apply grease using a grease gun with a needle nose adapter or a tube-type applicator such as Sta-lube Moly-graph Assembly Lube (Fig.6). These can be obtained at most auto parts stores.
2. Use a light oil such as WD-40 on the hub (Fig.7). Check caster for damage and test caster spin and swivel rotation before returning to service.

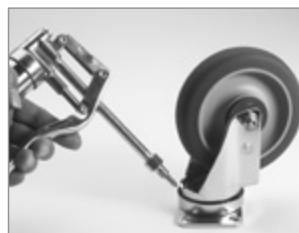

Fig. 6



Fig. 7

OPTIONAL ACCESSORIES

CODE	DESCRIPTION	FITS	OVERALL DIMENSIONS L x W x H
CB1220	Cutting Board	CVC724, CVC55	21" x 13 $\frac{1}{8}$ " x $\frac{1}{2}$ "
1200DIV	ThermoBarrier	CVC724, CVC72	20 $\frac{7}{8}$ " x 13 $\frac{1}{8}$ " x 1 $\frac{3}{8}$ "
CP1220	Full GN Camchiller	CVC724, CVC55	20 $\frac{1}{16}$ " x 12 $\frac{7}{8}$ " x 1 $\frac{1}{2}$ "
CP1210	$\frac{1}{2}$ GN Camchiller	CVC724, CVC55	10 $\frac{3}{16}$ " x 12 $\frac{3}{4}$ " x 1 $\frac{1}{2}$ "
CP814	Camchiller	CVC724, CVC72	14" x 8" x 1 $\frac{1}{2}$ "
DIV12	Divider Bar	CVC724, CVC55	12 $\frac{3}{4}$ " L
WCR1220	Well Cover	CVC724, CVC55	21" x 13" x 2"
730STP	Retainer Strap	CVC55	—

DIV12 Case Pack: 3 Retainer Strap Case Pack: 2 Case Pack: 1- All Others

IV. Replacement Parts

Please visit www.cambro.com for a complete list of replacement parts.
The model number of the Cambro Camcruiser® is required to determine the correct replacement part.

TO ORDER REPLACEMENT PARTS:

- Call Cambro Customer Service at 800 833 3003 or
- Call International 714 848 1555
- Fax your order to 714 842 3430 or
- Call your local Cambro Representative or Distributor

V. Warranty

Cambro warrants to the original buyer that if a product proves defective:

1. Within 1 year from the date of manufacture, Cambro will replace the product free of charge; or,
2. After 1 year and up to 2 years from the date of manufacture, Cambro will grant a credit of 2/3 off replacement product; or,
3. After 2 years and up to 3 years from the date of manufacture, Cambro will grant a credit of 1/3 of the original price towards a replacement product.